



GUIDANCE NOTES
GD08-2021

ISClass

INTERNATIONAL SHIP CLASSIFICATION

**GUIDELINES FOR SURVEY OF
ADDITIVE MANUFACTURING**

2021

Effective from 1 June, 2021

INTRODUCTION

ISC Guidelines for Survey of Additive Manufacturing were developed based on recognized standards of additive manufacturing and special requirements of ships, with the main focus on metal materials. The Guidelines introduced four aspects, i.e., additive manufacturing principles and processes, additive manufacturing design principles and assessment, approval of additive manufacturing, and inspection of additive manufactured products, thus providing inspection and approval standards for marine additive design, product manufacturing and additive repair.

CONTENTS

| | |
|---|-----------|
| CHAPTER 1 GENERAL | 1 |
| 1.1 Purpose | 1 |
| 1.2 Application | 1 |
| 1.3 Terms and definitions | 1 |
| 1.4 Additive manufacturing raw material and product approval process | 1 |
| CHAPTER 2 ADDITIVE MANUFACTURING PRINCIPLES AND PROCESSES | 2 |
| 2.1 General provisions | 2 |
| 2.2 Process characteristics..... | 2 |
| 2.3 Category of basic process | 2 |
| CHAPTER 3 ADDITIVE MANUFACTURING DESIGN PRINCIPLES AND ASSESSMENT | 5 |
| 3.1 General provisions | 5 |
| 3.2 Design assessment of additive manufacturing..... | 5 |
| 3.3 Design principles and assessment of additive repair | 6 |
| CHAPTER 4 APPROVAL OF ADDITIVE MANUFACTURING | 8 |
| 4.1 General provisions | 8 |
| 4.2 Works approval of raw materials for additive manufacturing..... | 8 |
| 4.3 Works approval and type approval of additive manufactured products | 12 |
| 4.4 Approval of additive repair process | 14 |
| CHAPTER 5 INSPECTION OF ADDITIVE MANUFACTURED PRODUCTS | 18 |
| 5.1 General provisions | 18 |
| 5.2 Specimen preparation..... | 18 |
| 5.3 Additional features of additive manufactured products | 18 |
| 5.4 Inspection basis..... | 18 |
| 5.5 Acceptance criteria..... | 18 |
| 5.6 Test report..... | 19 |
| APPENDIX A DOCUMENTS TO BE SUBMITTED FOR APPROVAL OF ADDITIVE MANUFACTURING RAW MATERIALS, PRODUCTS AND REPAIR PROCESSES | 20 |
| APPENDIX B FLOWCHART OF APPLICATION OF INDUSTRIAL CT DETECTION IN ADDITIVE MANUFACTURING | 21 |
| APPENDIX C FRAME DIAGRAM OF ADDITIVE MANUFACTURING DATABASE | 22 |

Chapter 1 General

1.1 Purpose

1.1.1 The Guidelines provide inspection basis for the use of additive manufacturing (generally referred to as 3D printing) for raw materials, products and repair processes.

1.1.2 Products designed, manufactured and repaired through additive manufacturing are to be inspected by ISC in accordance with the Guidelines. For those not listed in the Guidelines, their chemical composition, mechanical properties and post surface processing may be accepted in accordance with relevant recognized standards, subject to the approval of ISC.

1.2 Application

1.2.1 The Guidelines are applicable to additive manufacturing and repairing processes mainly based on powder bed fusion, wire arc deposition and directed energy deposition. Other additive manufacturing processes and materials are specially considered.

1.3 Terms and definitions

1.3.1 Some commonly used terms and definitions related to additive manufacturing technology are listed below:

- (1) Additive manufacturing: A process by which digital 3D design data is used to build up a part or an object in layers by depositing material.
- (2) Powder bed fusion: Additive manufacturing process in which thermal energy selectively fuses regions of a powder bed.
- (3) Wire arc deposition: Additive manufacturing process in which arcs are used to fuse wires by melting as they are being deposited.
- (4) Directed energy deposition: Additive manufacturing process in which lasers are used to fuse powdered materials by melting as they are being deposited.
- (5) Additive repair: A process that carries out depositing or melting repair to formed products by means of various additive manufacturing processes.
- (6) Additive manufacturing products: functional parts (components) formed by additive manufacturing processes, which are expected complete products or their components
- (7) Additive manufacturing prototype: The first batch of products (components) that are formed by the additive manufacturing process for testing or mass production.

1.3.2 For other terms and definitions used in the Guidelines, refer to GB/T 35351, ASTM F2792-12a and ISO 17296-1 or related recognized standards.

1.4 Additive manufacturing raw material and product approval process

1.4.1 Additive manufacturing raw material and product approval process is given in Figure 1.4.1 of this Chapter. For certification process, reference may be made to relevant requirements of Chapter 3, PART ONE of ISC Rules for Classification of Sea-going Steel Ships.

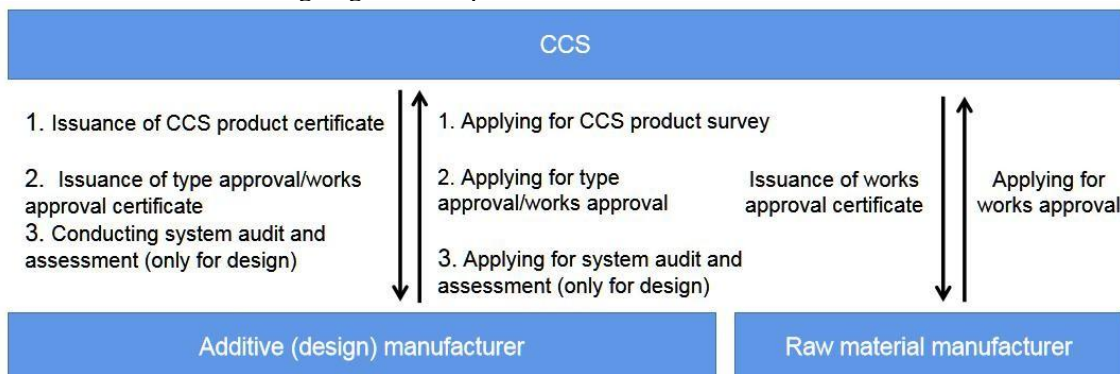

Figure 1.4.1 Approval process of raw materials and products by additive manufacturing

Chapter 2 Additive Manufacturing Principles and Processes

2.1 General provisions

2.1.1 This Chapter introduces different additive manufacturing principles and processes applicable to marine products and repairs.

2.1.2 For other additive manufacturing principles and processes, reference may be made to other recognized standards (e.g. ISO 17296-2).

2.2 Process characteristics

2.2.1 Parts produced by additive manufacturing can be used as both prototypes and production parts. Production parts reflect expected requirements of the designer at the end of the product development. For both prototypes and production parts, different processes and materials can be used depending on the product type, scope of application, cost and lead time requirements.

2.2.2 Parts are divided into different classes, from the most rigorous class regarding quality and traceability to the least rigorous class regarding quality and traceability. The details of these classes and requirements are given in standards related to the feedstock, process and application.

2.2.3 The process chain involved in additive manufacturing technologies is characterized by direct fabrication of parts based on computer-aided design (CAD) 3D data. Intermediate states, such as mold manufacturing, are unnecessary.

2.2.4 The additive manufacturing process chain consists of two categories:

(1) Single-step processes: parts are fabricated in a single operation where the basic geometric shape and basic material properties of the intended products are achieved simultaneously.

(2) Multi-step processes: parts are fabricated in two or more operations where the first typically provides the basic geometric shape and the following consolidates the part to the intended basic material properties.

2.2.5 Appropriate post-processing operations to reduce surface roughness and improve surface finish, dimensional accuracy and material properties, e.g. micro blasting, machining, grinding, laser re-melting, polishing and heat treatments are required for additive manufacturing and additive repair to reach all the intended properties in the final product.

2.2.6 Taking into account the existence of residual stress in additive manufacturing products/repairs, the manufacturer may carry out heat treatment or other stress relief treatment in accordance with relevant recognized standards with the consent of ISC. In order to increase the material density and eliminate pores and voids in the product, the manufacturer may carry out the hot pressing process in accordance with relevant recognized standards with the approval of ISC.

2.2.7 In the process of removing the clamp or bracket for the additive manufacturing product/repairs, the manufacturer is to pay attention to the impact of these operations on the integrity of the product. The post-processing process needs to be carried out on the prototype at the same time.

2.3 Category of basic process

2.3.1 Additive manufacturing technology includes a variety of process types. Metal additive manufacturing processes applicable to marine products may consist of powder bed fusion, wire arc deposition, directed energy deposition and additive repair.

2.3.2 Powder bed fusion: additive manufacturing process in which thermal energy selectively fuses regions of a powder bed. See Figure 2.3.2 of this Chapter.

(1) Feedstock: various powders: thermoplastic polymers, typically pure metals or metal alloys. Any of the powder materials could be used with, or without, fillers and binders depending on the specific process;

(2) Binding mechanism: thermal reaction bonding;

(3) Source of fusion: thermal energy, typically transferred from laser, electron beam etc;

(4) Secondary processing: removal of loose powder and support material, and various operations to improve surface finish, dimensional accuracy and material properties, e.g. micro blasting, finishing milling, grinding, polishing and heat treatments.

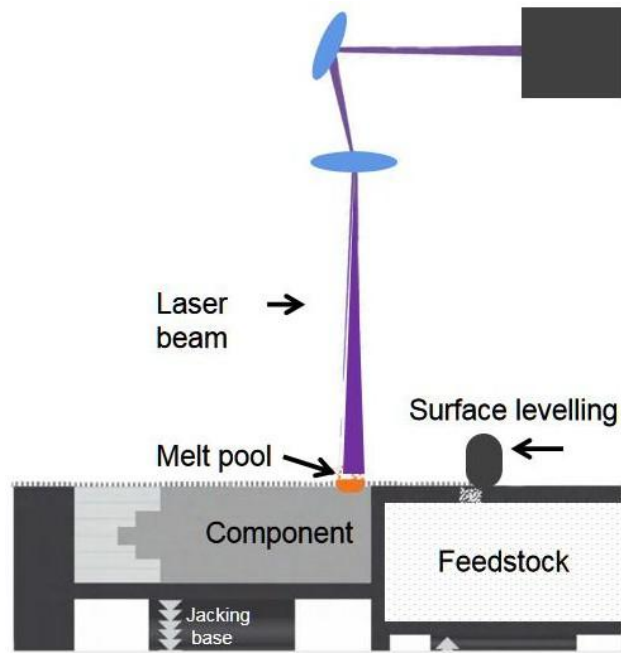

Figure 2.3.2 Powder bed fusion process

2.3.3 Wire arc deposition: additive manufacturing process in which arcs are used to fuse wires by melting as they are being deposited. See Figure 2.3.3 of this Chapter.

- (1) Feedstock: wire for welding (generally metal). Other materials can be added to the wire in use according to the requirements of the process;
- (2) Binding mechanism: solidification through thermal reaction;
- (3) Source of fusion: arc, arc-laser composite heat source;
- (4) Secondary processing: various operations to reduce surface roughness and improve surface finish, dimensional accuracy and material properties, e.g. micro blasting, machining, grinding, laser re-melting, polishing and heat treatments.

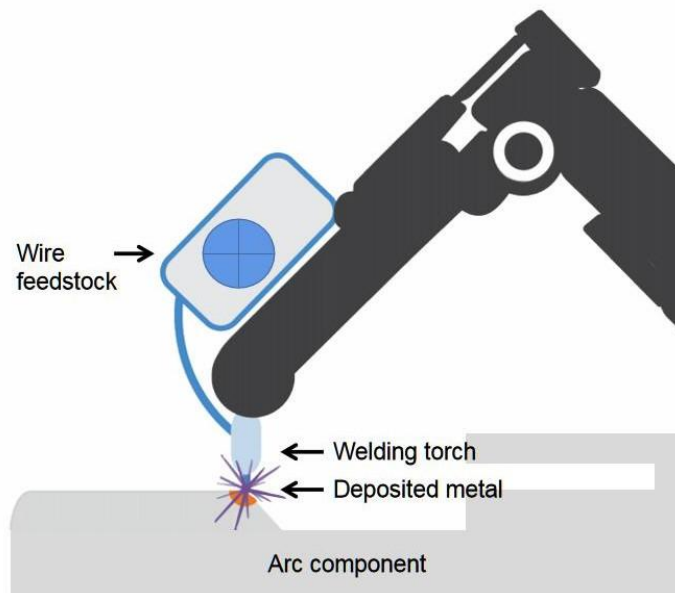

Figure 2.3.3 Wire arc deposition process

2.3.4 Directed energy deposition: additive manufacturing process in which lasers are used to fuse powdered materials by melting as they are being deposited. See Figure 2.3.4 of this Chapter.

- (1) Feedstock: powder, typically metal, for certain applications ceramic particles can be added to the base material;
- (2) Binding mechanism: solidification through thermal reaction;

- (3) Source of fusion: laser, electron beam or plasma beam;
- (4) Secondary processing: various operations to reduce surface roughness and improve surface finish, dimensional accuracy and material properties, e.g. micro blasting, machining, grinding, laser re-melting, polishing and heat treatments.

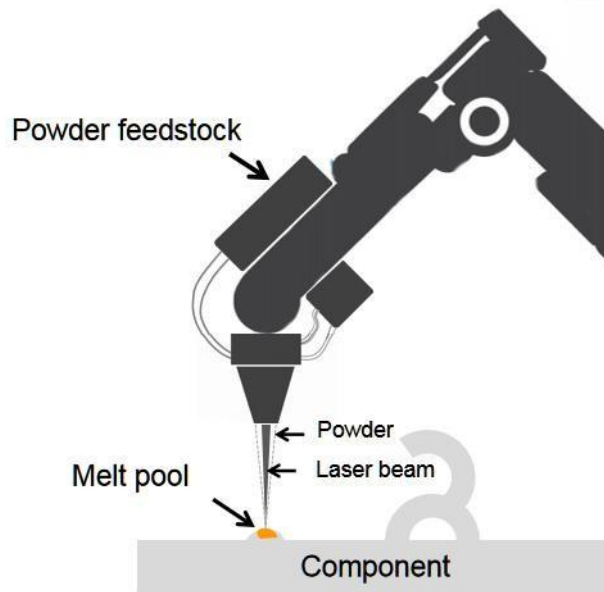

Figure 2.3.4 Directed energy deposition process

2.3.5 Additive repair: a process in which the selected coating material is placed on the surface of the coated substrate with different filler methods, which is melted with a thin layer of the substrate surface at the same time by laser irradiation to form a surface coating with a very low dilution and metallurgical combination with substrate material after quick solidification, so as to repair the damaged product surface or significantly improve the wear resistance, corrosion resistance, heat resistance, oxidation resistance and electrical properties of the substrate material surface.

(1) Feedstock: powder and wire;

(2) The process includes the contents of 2.3.2, 2.3.3 and 2.3.4;

(3) Repair treatment: grooves are to be polished to a smooth transition zone before repair. Magnetic particle testing or penetrant testing is to be used to verify whether the defects are completely removed after repair.

2.3.6 Other common additive manufacturing processes include vat photopolymerization, binder jetting, material jetting and material extrusion, which may be carried out by referring to relevant recognized standards with the consent of ISC.

Chapter 3 Additive Manufacturing Design Principles and Assessment

3.1 General provisions

3.1.1 This Chapter introduces design principles and assessment of additive manufacturing products, generally consisting of traditional design process and new design. For the traditional design process, design is carried out by combining the empirical design with simulation check. For the new design process, simulation-driven and innovative design is carried out by establishing an innovative infrastructure of new materials and using high-throughput computing. See Figure 3.1.1 of this Chapter.

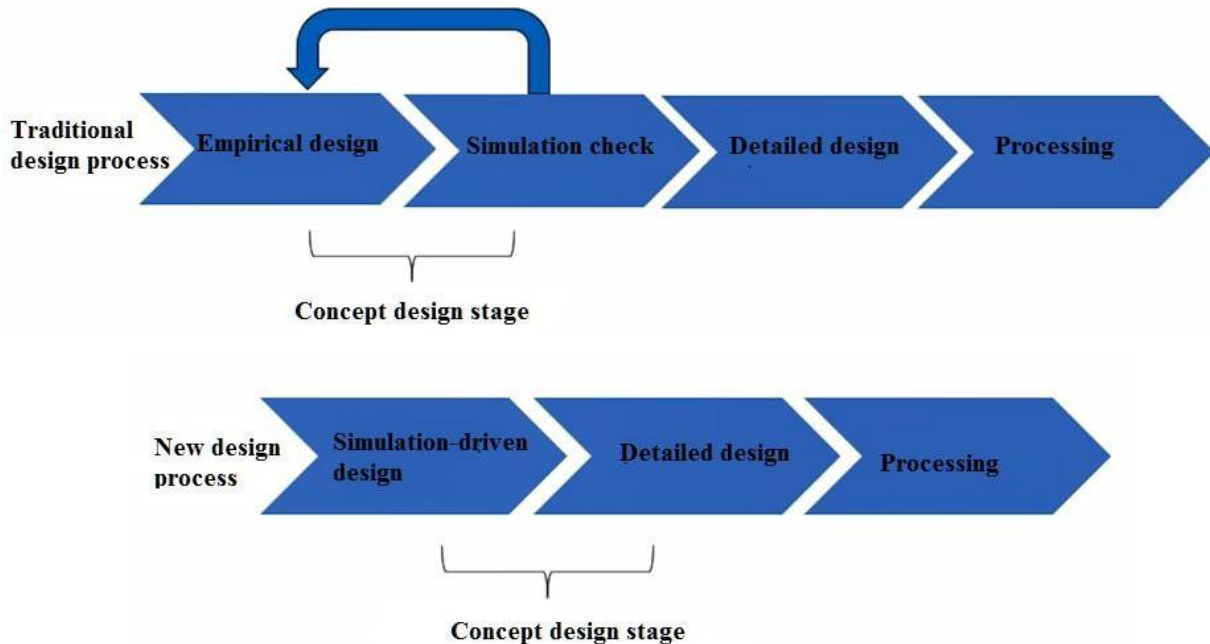

Figure 3.1.1 Comparison between two types of additive manufacturing design flowcharts

3.1.2 At the design stage of additive manufacturing, product requirements and additive manufacturing design plans need to be specified in detail and approved by ISC. The additive manufacturing design plan needs to include raw materials, process methods, post-processing and product performance.

3.1.3 The designer of additive manufacturing or repair needs to pass ISC quality system verification requirements. For related requirements, refer to Section 9, Chapter 3, PART ONE of ISC Rules for Classification of Sea-going Steel Ships.

3.2 Design assessment of additive manufacturing

3.2.1 System audit and design assessment: unless expressly provided, ISC does not require design approval of additive manufacturing, but system audit and design assessment need to be carried out to the designer. Customers need to submit the following technical materials for information at system audit and design assessment during additive manufacturing of new products and development of new technologies, including:

- (1) Customized service plan;
- (2) The acceptable safety level, which is used to reduce the uncertainty in the later stage of the product;
- (3) Meeting the needs of early market expansion;
- (4) Universal design and technical solutions;
- (5) Alternative design plan;
- (6) Solutions to avoid the risk of non-conformity of system performance.

3.2.2 Control and assessment at the design stage: an effective system of control and assessment of design requirements is to be established for product design of additive manufacturing, and it is to be ensured that the following stages are controlled:

- (1) Reducing the total number of parts;
- (2) The function/multi-function design is perfect and the powder leakage hole is considered;
- (3) Light/simple optimization;
- (4) Easy to manufacture;

(5) Material degradation or bracket (deliberately designed defects) design and control of deformation during the additive process;

(6) Hybrid design solutions.

3.2.3 During the additive design, material mechanical properties are to be defined which are necessary to ensure that the design of the product is suitable with due consideration to the functions, applied loads, service environment and failure modes of the product, typically:

(1) tensile properties and hardness;

(2) fracture properties (typically Charpy V-notch impact test value, crack tip opening displacement (CTOD) test value);

(3) fatigue properties (typically S/N curves, crack propagation rates) including in specific environments as applicable;

(4) corrosion resistance properties (general corrosion, specific types of corrosion like pitting, crevice and stress corrosion cracking), as applicable to the specific environments;

(5) Z-direction properties (if any).

3.2.4 During the design process of additive manufacturing, the concepts of agile manufacturing and intelligent manufacturing may be considered, and effective organic integration methods (such as databases) are to be established to ensure that they are reasonable and effective in design and product application.

3.2.5 The final data of additive design is to be selectively submitted to ISC by the designer, which is to submit the design rules for related products to ISC. When referring to the applicable classification rules, special attention is to be paid to the consistency of the material data as design assumptions. The non-destructive examination plan is to be submitted to ISC for review. The plan is to include magnetic particle or liquid penetrant testing, ultrasonic testing, industrial CT testing and radiographic testing. Detailed instructions are to be included in the plan.

3.2.6 The integrated assessment process of new design and manufacturing for marine additive manufacturing is shown in Figure 3.2.6 of this Chapter.

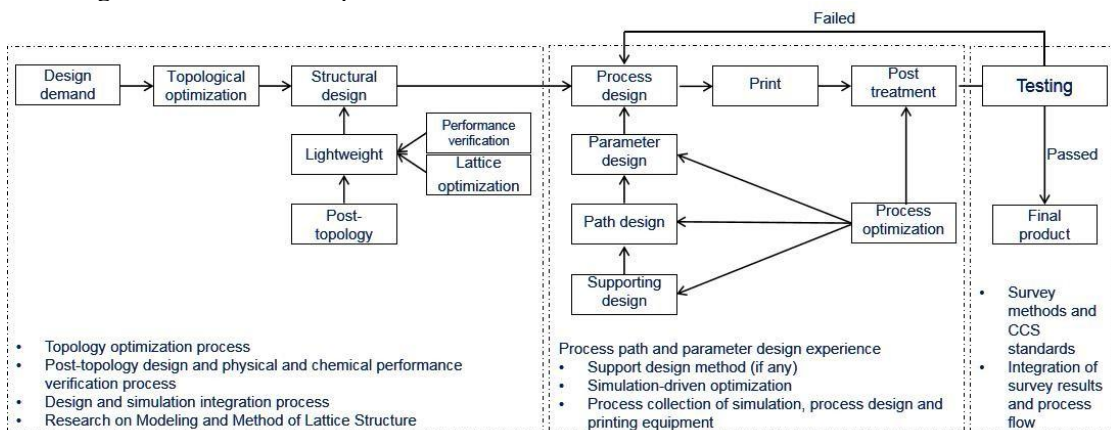

Figure 3.2.6 Integrated assessment process for innovative design and manufacturing of marine additive manufacturing

3.2.7 In addition to this section, product design of additive manufacturing may refer to recognized standards such as ISO 17296-4 or ISO/ASTM 52915-13 etc.

3.3 Design principles and assessment of additive repair

3.3.1 Compared with the traditional repair processes, additive repair has the advantages of lower dilution rate, small heat-affected zone, metallurgical bonding, less distortion and deformation of cladding parts, and easy realization of the automation of process. The design process of additive repair processes are shown in Figure 3.3.1.

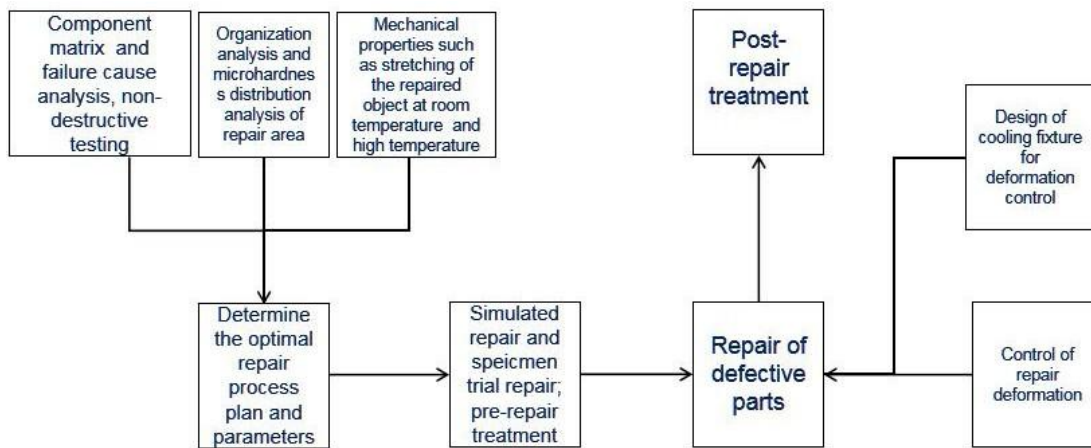

Figure 3.3.1 Design and assessment process for marine additive repair

3.3.2 Additive repair is generally a repair process carried out to wear or corroded position of parts or products; therefore, the designer is to submit the condition regarding the wear or corrosion of parts or products to ISC for assessment.

Chapter 4 Approval of Additive Manufacturing

4.1 General provisions

4.1.1 Manufacturers producing raw materials for additive manufacturing are to obtain ISC works approval; manufacturers producing additive manufacturing products are to obtain ISC works approval or type approval; additive repair processes need to be approved by ISC.

4.1.2 The approval of additive manufacturing products is, in addition to satisfying inspection requirement in Chapter 5 of these Guidelines, to satisfy requirements of ISC Rules for Materials and Welding, Rules for Classification of Sea-going Steel Ships, and Guidelines for Survey of Marine Products.

4.1.3 In addition to 4.4 of this Chapter, the approval of additive repair processes may refer to welding procedure approval in ISC Rules for Materials and Welding.

4.1.4 The approval certificate of additive manufacturing and repair processes is to include documents required to be submitted to ISC, see Appendix A of these Guidelines.

4.2 Works approval of raw materials for additive manufacturing

4.2.1 Scope of application

4.2.1.1 This section is applicable to works approval of raw materials for additive manufacturing which are manufactured in accordance with relevant requirements of recognized standards accepted by ISC.

4.2.1.2 This section specifies testing methods of metallic wires or powders (hereinafter referred to as raw materials) and applies to works approval of wires and powders for additive manufacturing of normal and high strength steels, extra high strength steels, austenitic/duplex stainless steels and aluminium bronze. Other types of raw materials may be considered with the consent of ISC.

4.2.1.3 In addition to testing methods of raw materials (metals) specified in this section, testing methods of other raw materials (e.g. non-metals, ceramics, etc.) may refer to ISO 17296-3 or other recognized standards.

4.2.1.4 The manufacturer is to have obtained the quality management system certificate based on ISO 9000 or equivalent standards issued by the certification body and maintain the validity of the certificate.

4.2.2 Grading and designation

4.2.2.1 Raw materials are in general classified with a grade depending on the mechanical property, chemical composition and other chemical and mechanical properties of the deposited metal. For different products or materials, grades of raw materials may be considered as appropriate. Non-metallic materials are to be specially considered by ISC.

4.2.2.2 Where shielding gas is used, the type of shielding gas used is to be submitted to ISC by the manufacturer. The classification of the shielding gas is to be in accordance with the standard ISO 14175 or relevant recognized standards.

4.2.3 Works approval

4.2.3.1 The manufacturer is to submit information related to raw materials to ISC in accordance with relevant requirements of Section 5, Chapter 3, PART ONE of ISC Rules for Classification of Sea-going Steel Ships.

4.2.3.2 The type approval tests are to be performed on samples representative of raw materials. Sampling procedures are to be agreed with ISC surveyor.

4.2.3.3 The inspection of the test samples and the tests are to be carried out in the presence of ISC surveyor. Unless otherwise specified, test specimens and procedures are to be in accordance with ISC requirements or recognized standards accepted by ISC.

4.2.3.4 Upon satisfactory completion of the approval tests, a certificate of works approval is issued by ISC to the manufacturer. The certificate states the grade under which the raw material has been approved and the terms of validity of the certificate.

4.2.3.5 The method of production and quality control of raw materials are to be such as to ensure reasonable uniformity in manufacture. A packaging sufficiently strong to resist the usual transportation and handling operations is to be supplied. The manufacturer is to stamp on each packaging the markings which are necessary to trace back each production.

4.2.3.6 The manufacturer is to take full responsibility for the quality and standards of raw materials. The manufacturer is to keep up-to-date records of the manufacture of the works approved raw materials, including

details of the history of the single productions and results of associated tests. ISC is to have free access to these records at all times.

4.2.3.7 The manufacturer is responsible for reporting to ISC any major modifications introduced in the production procedure subsequent to its type approval. Where it is deemed by ISC that such major modifications may lead to relatively large change to the performance of raw materials (e.g. change of grading), approval tests need to be carried out again to the raw material.

4.2.4 Works approval type tests

4.2.4.1 Works approval type tests of raw materials for additive manufacturing generally include physical and chemical performance test of wire or powder and test piece performance test.

4.2.4.2 Physical and chemical performance test of powder materials

Safety and health factors are to be considered during the selection, storage, transportation and reuse of powder materials for additive manufacturing process. Approval tests are to be carried out in accordance with the standards in Table 4.2.4.2 of this Chapter. Other equivalent recognized standards may also be referred to with the consent of ISC. The inspection results are to meet relevant recognized standards or meet the acceptance standards set by the design.

Main characteristics of power and testing methods of recognized standards

Table 4.2.4.2

| Item | Metal ^① | Plastics ^① |
|---------------------------------------|--|------------------------------------|
| Powder particle size and distribution | ISO 4497 ISO 8130-1 ISO 13319 ISO 13320 | ISO 4610 ISO 13319 ISO 13320 |
| Morphology | ISO 9276-6 | ISO 9276-6 |
| Density | ISO 3923-1 ISO 3923-2 | ISO 1068 |
| Flowability | ISO 4490 | ISO 6186 ISO 4324 |
| Chemical composition | ISO 7625 | - |

① The Guidelines are only applicable to testing standards of common metal and plastic materials in additive manufacturing. If other materials are involved in the design plan of additive manufacturing, reference may be made to relevant recognized standards with the consent of ISC.

4.2.4.3 Physical and chemical performance test of wire materials

Wire materials for additive manufacturing process are to be subject to inspection of dimensional accuracy, surface finish and chemical composition. The inspection results are to meet relevant recognized standards or meet the acceptance standards set by the design.

4.2.5 Test piece performance test of additive manufacturing process

4.2.5.1 Process test pieces for performance testing are to be manufactured by printing from powder materials and wires used in the additive manufacturing process in accordance with the process and process parameters recommended by the additive manufacturing manufacturer. The size of the process test piece is to meet the requirements of subsequent preparation of test specimens, considering the possibility of retesting. For tensile, impact and bend tests required in Table 4.2.5.1 of this Chapter, the same number of test specimens is to be taken from three test directions of X, Y, and Z for the test. The coordinate system of the test specimen direction is to comply with ISO/ASTM 52921 or relevant recognized standards. Test results in the three directions are to meet the minimum performance requirements of the test piece.

Test items and standards of additive manufacturing process test panel

Table 4.2.5.1

| Item | Reference standards |
|--|--|
| Tensile performance | Rules for Materials and Welding |
| Impact performance | Rules for Materials and Welding |
| Bend test | Rules for Materials and Welding or relevant recognized standards |
| Radiographic testing | ISO 5579 |
| Ultrasonic testing, | ISO 11666 or relevant recognized standards |
| Liquid penetrant testing/magnetic particle testing | ISO 3452-1, ISO 3452-2/ ISO 9934-1 |
| Chemical composition | Relevant recognized standards |

4.2.5.2 Mechanical properties of normal and high strength steels, austenitic/duplex stainless steels are to comply with the requirements of Table 4.2.5.2 of this Chapter.

Requirements for mechanical properties

Table 4.2.5.2

| Grade | Tensile test | | | Impact test | |
|------------------------------------|--|--|----------------------------|--|---|
| | Yield stress R _{eH} or R _{p0.2} Min. (N/mm ²) | Tensile strength R _m Min. (N/mm ²) | Elong. A Min. (%) | Test temp. (°C) | Minimum average energy ^① (J) |
| A | 305 | 400-560 | 22 | + 20 | 34 |
| B, D | | | | 0 | |
| E | | | | -20 | |
| AH32 | 335 | 440-600 | 22 | + 20 | 34 |
| DH32 | | | | 0 | |
| EH32 | | | | -20 | |
| FH32 | | | | -40 | |
| AH36 | 375 | 490-660 | 22 | + 20 | 34 |
| DH36 | | | | 0 | |
| EH36 | | | | -20 | |
| FH36 | | | | -40 | |
| DH40 | 400 | 510-690 | 22 | 0 | 39 |
| EH40 | | | | -20 | |
| FH40 | | | | -40 | |
| DH420 | 420 | 530-680 | 20 | -20 | 47 |
| EH420 | | | | -40 | |
| FH420 | | | | -60 | |
| DH460 | 460 | 570-720 | 20 | -20 | 47 |
| EH460 | | | | -40 | |
| FH460 | | | | -60 | |
| DH500 | 500 | 610-770 | 18 | -20 | 50 |
| EH500 | | | | -40 | |
| FH500 | | | | -60 | |
| DH550 | 550 | 670-830 | 18 | -20 | 55 |
| EH550 | | | | -40 | |
| FH550 | | | | -60 | |
| DH620 | 620 | 720-890 | 18 | -20 | 62 |
| EH620 | | | | -40 | |
| FH620 | | | | -60 | |
| DH690 | 690 | 770-940 | 17 | -20 | 69 |
| EH690 | | | | -40 | |
| FH690 | | | | -60 | |
| Austenitic stainless steels | | | | | |
| 304L, 316L, 317L, 309L | 270 | 500 | 25 | -20 (When austenitic stainless steels are used in cryogenic conditions, the impact test is to be carried out at -196°C) | 27 |
| 304LN, 316LN, 317LN, 347 | 290 | 550 | 22 | | |
| 304, 316, 317, 309 | 290 | 550 | 25 | | |

| Duplex stainless steels | | | | | |
|-------------------------|-----|-----|----|-----|----|
| S2205 | 450 | 620 | 25 | -20 | 27 |
| S2550 | 550 | 690 | 15 | | |
| S2750 | 550 | 790 | 15 | | |

Note: ① Impact test direction is generally not required unless requested by the purchaser or ISC.

4.2.5.3 The chemical composition analysis, metallographic inspection and mechanical properties of aluminum alloy and bronze raw materials are to meet the relevant requirements of the Rules for Materials and Welding. Reference may be made to ISO 24373 or other recognized standards with the consent of ISC.

4.2.5.4 After completion of the approval test, the manufacturer is to submit a raw material approval test report to ISC. The content of the test report is to include the following:

- (1) Test date, test environment and raw material pre-treatment status;
- (2) The approved grade, brand, type and specification of raw materials;
- (3) Additive process;
- (4) Type of additive equipment and shielding gas composition;
- (5) Results of various tests;
- (6) On-site record sheet of manufacturing test piece;
- (7) The coordinate system expression of test specimens.

4.2.6 Maintenance of approval

4.2.6.1 Additive manufacturing raw materials which have been works approved are to be subjected to annual inspection so as to maintain the approval of the raw materials. Any additive manufacturing raw material approved by ISC is normally to be inspected and tested annually by the surveyor on site. The annual tests are to include the following:

- (1) Powder materials: the physical and chemical properties of powder materials are in compliance with the requirements of 4.2.4.2, and one process test piece is prepared and tests of the process test piece are carried out according to the provisions of 4.2.5 in this Chapter at the same time;
- (2) Wire materials: the physical and chemical properties of wire materials are in compliance with the requirements of 4.2.4.3, and one process test piece is prepared and tests of process test piece are carried out according to the provisions of 4.2.5 in this Chapter at the same time.

4.2.6.2 In the following circumstances, ISC will notify the additive manufacturing raw material manufacturer that the approval of its product is withdrawn:

- (1) Failure to carry out annual inspection and test without special reasons;
- (2) Sampling inspection shows that the quality of the product is significantly lower than that at the time of approval so that the product is unqualified;
- (3) Major defects occur in the management system, proper corrective measures are not taken, and thus the accuracy, reliability and fairness of test results are not ensured;
- (4) Additive manufacturing raw materials are not inspected and tested in accordance with the approved test procedures and standards, etc.;
- (5) Failure to pay the relevant fees to ISC.

4.2.7 Certificate

4.2.7.1 The works approval certificate for additive manufacturing raw materials is to contain at least the following:

- (1) Name, brand, specifications and usage of the material;
- (2) Acceptance basis (rules, standards, technical agreements, etc.);
- (3) Delivery condition.

4.2.7.2 Approved additive manufacturing raw materials are to be attached with a quality instruction which is to contain at least the following:

- (1) Brand and approval grade;
- (2) The name or symbol of the manufacturer;
- (3) The type of shielding gas used;
- (4) Recommended storage environmental conditions for raw materials;
- (5) Hazards and safety instructions (powder materials);
- (6) Date of manufacture and batch number;
- (7) Scantling or particle size (if any).

4.3 Works approval and type approval of additive manufactured products

4.3.1 Scope of application

4.3.1.1 This paragraph applies to works approval and type approval for additive manufactured products. Additive manufactured products and associated components are to be approved in accordance with the List of Certification Requirements in Appendices 1 and 2, Chapter 3, PART ONE of ISC Rules for Classification of Sea-going Steel Ships.

4.3.1.2 In addition to complying with the requirements of ISC Rules for Materials and Welding and Guidelines for Survey of Marine Products, the approval of relevant additive manufactured products is also to comply with the requirements of 4.3 of this chapter.

4.3.1.3 Works approval and type approval for additive manufactured products are applicable to products that are mass-produced by continuous process using additive manufacturing technology, or products the quality of which is guaranteed entirely through the control of manufacturing procedures and production process.

4.3.1.4 The manufacturer should already have obtained and maintained the quality management system certificate issued by the certification authority based on ISO 9000 or equivalent standards.

4.3.1.5 Works approval and type approval of additive manufactured products may be carried out by referring to Chapter 3, PART ONE of ISC Rules for Classification of Sea-going Steel Ships.

4.3.2 Approval and approval items

4.3.2.1 When approving additive manufactured products, the approval items for corresponding products required in ISC Rules for Materials and Welding, Rules for Classification of Sea-going Steel Ships and Guidelines for Survey of Marine Products are to be complied with. In addition to that, the test standards for different products are also to comply with the specimen preparation requirements in Chapter 5 of the Guidelines and the requirements in Table 4.3.2.1 of this Chapter on Approval item tests for additive manufactured products.

Approval Item Tests (including type test) for Additive Manufactured Products

Table 4.3.2.1

| Properties | Item | Recognized standards [®] that can be referred to in addition to ISC Rules for Materials and Welding | |
|-------------------------------------|---|---|--|
| | | Metal | Plastic |
| Appearance and geometric properties | Length and angle dimensional tolerances | ISO 129-1 ISO 286-1 ISO 14405-1 ISO 1938-1C ISO 2768-1 | ISO 129-1 ISO 286-1 ISO 14405-1 ISO 1938-1C ISO 2768-1 |
| | Appearance and microstructure test | ③ | ③ |
| Mechanical properties | Hardness | ISO 6506-1 ASTM E10 | ISO 2039 ISO 868 |
| | Fatigue performance(if any) | ISO 1099 ASTM E606 | ISO 13003 ISO 15850 |
| Non-destructive test | Magnetic particle test | ISO 9934-1 | - |
| | Penetrant test | ISO 3452-1 | ISO 3452-1 |
| | | ISO 3452-2 | ISO 3452-2 |
| | Eddy current testing | ASTM E2884 | ③ |
| | Industrial CT test [®] | ASTM E1441 | ASTM E1441 |
| Radiographic test | CB/T 3558 | ③ | |

| | | | |
|--|-----------------|---|---|
| | Ultrasonic Test | ③ | ③ |
|--|-----------------|---|---|

Notes: ① The Guidelines are only applicable to test standards for common metal and plastic materials used in additive manufacturing. If other materials are involved in additive manufacturing design, relevant recognized standards may be referred to subject to the consent of ISC;

② The flow chart of application of industrial CT test in additive manufacturing is shown in Appendix B of this chapter;

③ Other equivalent recognized standards may be referred to subject to the agreement of ISC.

4.3.2.2 Products that an additive manufacturer is capable of producing are all to be approved separately according to different types.

4.3.2.3 When the additive manufacturer manufactures the same type of products, if the type of raw material, basic additive principles, melting source and additive process are changed, re-approval is required. Figure 4.3.2.3 in this chapter shows the types of raw materials, basic additive principles, melting sources and additive process flow charts involved in the manufacturing or repair of metal additive manufactured products.

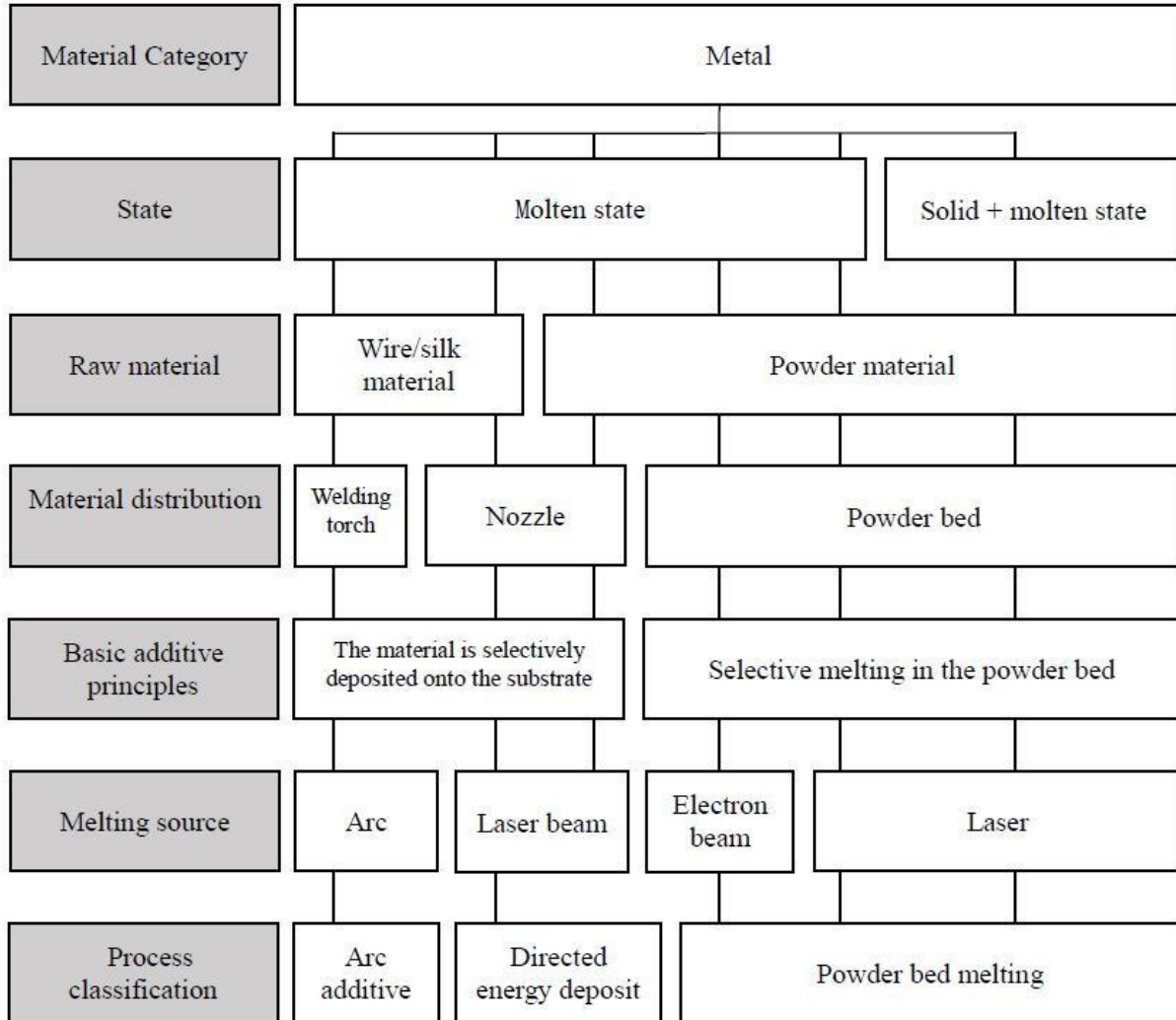

Figure 4.3.2.3 Metal material additive manufacturing process flow chart

4.3.3 Certificate

4.3.3.1 In addition to that to be included in the approval certificate for this category of products, the following items are to be additionally included in the approval certificates for additive manufactured products:

- (1) Specimen preparation method: molding direction, molding position (printed with the product g or printed separately), etc.;
- (2) Selection of raw material and protective gas;
- (3) Melting sources used in additive manufacturing and process classification;
- (4) Scheme for removing brackets for additive manufacturing (if any).

4.4 Approval of additive repair process

4.4.1 This paragraph applies to the approval of repair process for remanufacturing and repair of marine metal parts such as pumps, valves and cylinder liners by means of additive repair method. Prior to additive repair and remanufacturing, tests are to be carried out in accordance with this paragraph to determine the repair processes.

4.4.2 The regularly used repair processes include: arc fuse deposition repair technology, laser cladding technology, plasma cladding technology, thermal spraying repair technology and electro-deposition repair technology, etc.

4.4.3 The form of the specimen is to be determined according to the specific form of repair. The size and sampling position of the test piece is shown in Figure 4.4.3-(1) in this chapter. The edge preparation is shown in Figure 4.4.3-(2) of this chapter. Groove depth/build-up welding thickness D is not less than 15mm, or the design requirements are to be followed.

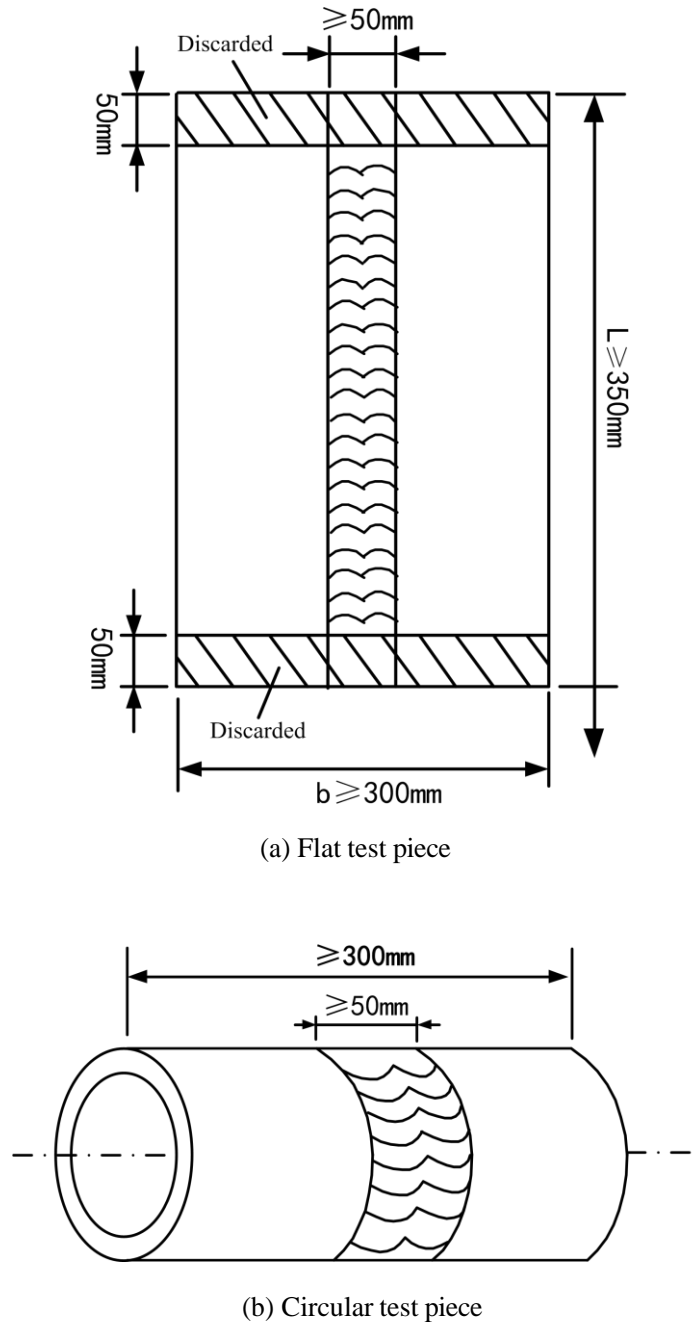

Figure 4.4.3-(1) Specimen size for additive repair process approval test

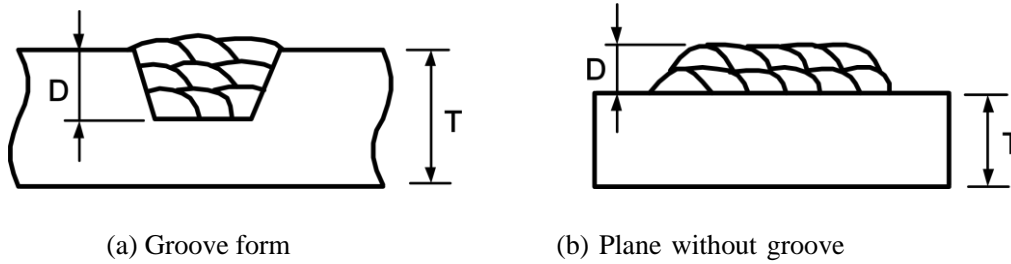
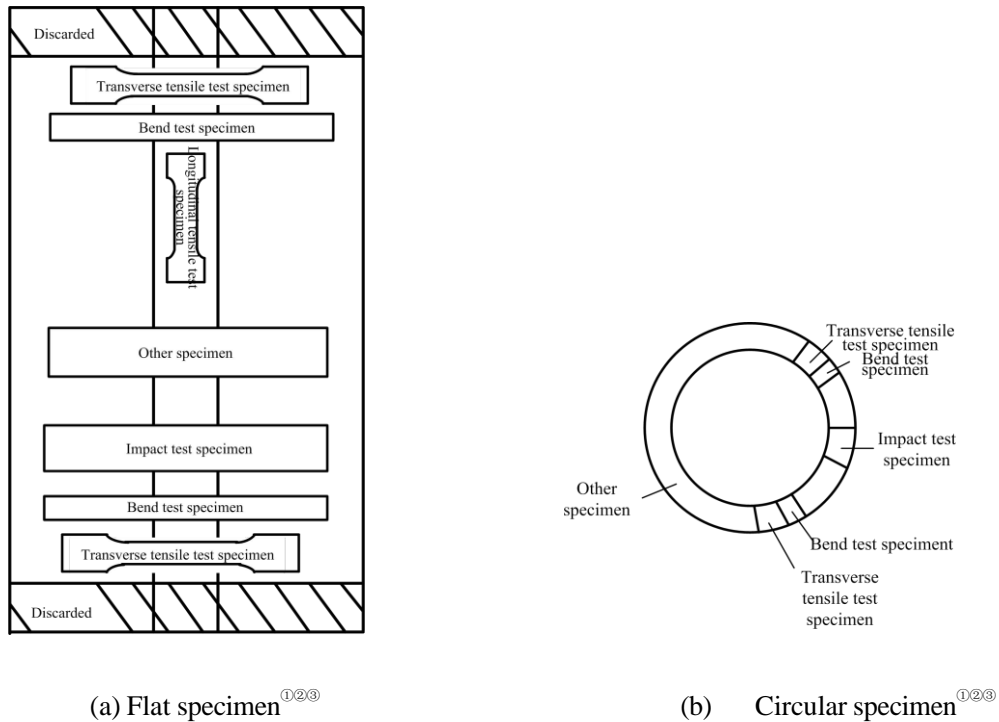

Figure 4.3.3-(2) Edge preparation of specimen

4.4.4 When conditions permit, 100% surface and internal non-destructive testing of the repaired specimens are to be carried out. For acceptance standards, refer to ISC Rules for Materials and Welding, and relevant recognized standards and design technology (requirements), etc.

4.4.5 The sampling position of the specimen is as shown in Figure 4.4.5 of this chapter. The manufacturer is to, according to the design requirements, select appropriate test items according to Table 4.4.5-(2)(but not limited to this Table) of this Chapter. The test methods and test results are to comply with the requirements in Table 4.4.5-(1) of this Chapter. If the specimen cannot be sampled due to the size, relevant tests may be exempted subject to the consent of ISC.



Notes:

- ① Tensile test specimen: usually one longitudinal specimen of full thickness is taken from the repair layer. 2 transverse specimens are desirable in case of circular specimens or if there are technical requirements.
- ② Bend test specimen: usually two face bend test specimens and two root bend test specimens are taken from the repair layer. If the thickness of the repair layer is greater than or equal to 12 mm, four side bend test specimens may be taken instead.
- ③ Impact test specimen: usually one group (three specimens) of specimens are taken from the repair layer. More specimens from the heat affected zone may be taken if there are technical requirements. For a test specimen which is plane without groove, heat affected zone impact test may be exempted.

Figure 4.4.5 Sampling position of specimen

Physical and chemical test method for additive repair process Table 4.4.5-(1)

| Test type | Sampling and test process | Test results requirements |
|--|---|---|
| (a) Tensile test (room and high temperature) | Refer to ISC Rules for Materials and Welding or relevant recognized standards | The minimum tensile strength not to be lower than the base metal value, or meet the design technical requirements |
| (b) Bending test | | The bended surface of the specimen is not to reveal any crack exceeding 3 mm |
| (c) Impact test | | Meeting the base metal requirements, or design technical requirements |
| (d) Hardness test | | The repair layer meets the design technical requirements, and the heat affected zone and base metal meet the recognized standards |
| (e) Macro section test | | Well fused, no defect |
| (f) Corrosion test | | Meet the design technical requirements |
| (g) Chemical composition | | Meet the design technical requirements |
| (h) Microstructure | | Meet the design technical requirements |

Additive Repair Process Approval Test Items Table 4.4.5-(2)

| Material | Test items |
|--|--|
| Structural steels and nonferrous metals for structural use | (a) (b) (c) (d) (e) |
| Corrosion resistant layer | (f) (g) (h) |
| Wear-resisting layer | (a) (c) (d) (e) (g) |
| Other material | According to design technical requirements |

4.4.6 See for The application scope of additive repair process approval test is given in Table 4.4.6 of this Chapter.

Application Scope of Additive Repair Process Approval Test Table 4.4.6

| Parameters | Scope of application | |
|----------------------------|--|--|
| | Test material | Applicable material |
| Base material | Structural steel | Refer to ISC Rules for Materials and Welding |
| | Stainless steel and non-ferrous metal | Same as approved test |
| Thickness of base material | T < 25mm | ≥ (T~2T) |
| | T ≥ 25mm | ≥ 25mm |
| Repair position | Only applicable to the same repair position as tested. When the maximum and minimum heat input positions are tested simultaneously, all repair positions can be applied except for the vertical downward position. | |
| Repair process method | Only applicable to the process method used in the additive repair process approval test. | |
| Filler material | Only applicable to the filler material used in the additive repair process approval test (including material chemical composition, material geometry) | |
| Repair process parameters | The same process parameters as the additive repair approval test, including the used electrical parameters, laser parameters, speed and other major process parameters | |
| Heat input (if any) | The approved heat input upper limit is 25% higher than the heat input upper limit during the repair test. The approved heat input lower limit is 25% lower than the heat input lower limit | |

| | |
|--|--|
| | during the repair test. |
| Preheating and interpass temperature(if any) | The minimum preheating temperature is not to be lower than the minimum preheating temperature used in the repair test. The maximum interpass temperature is not to be higher than that used in the repair test. |
| Heat Treatment | Post-weld heat treatment used in repair process test. |

4.4.7 If the test result of approval test does not comply with the requirements, re-test is to be carried out by referring to relevant items in ISC Rules for Materials and Welding. If the retest result is still not satisfactory, the repair process is to be re-developed and the approval test is to be re-carried out

4.4.8 Before conducting the approval test of additive repair process, the manufacturer is to prepare the additive repair process approval plan according to 4.4.3, 4.4.4 and 4.4.5 above and submit it to ISC for review. The fabrication process and test of additive repair specimens during the additive repair process approval test are to be witnessed by the ISC site surveyor. The parameters during the test are to be recorded in the additive repair process approval test report, which are to be signed by the surveyor.

4.4.9 The manufacturer is to prepare a complete additive repair process specification according to the results of the additive repair process approval test, and submit it together with the test report to ISC for approval, which are to be signed by the surveyor. Additive repair process specification includes but is not limited to the following:

- (1) Material and thickness of base material;
- (2) Type, form and specification of repair filler materials;
- (3) Type and main functional parameters of repaired equipment;
- (4) Design of edge preparation;
- (5) Main repair process parameters;
- (6) Preheating and temperature control;
- (7) Heat treatment and stress relief treatment.

4.4.10 The manufacturer carries out product repair in a workshop under the same technical and management conditions as the repair approval test. If the parameters of the approved additive repair process specification are changed, the changed part is to be submitted to the ISC for review. ISC will decide whether to re-conduct repair process approval test according to the changed details.

Chapter 5 Inspection of additive manufactured products

5.1 General provisions

5.1.1 Considering the difference between additive manufacturing process and conventional processes, this chapter introduces the specimen preparation method, additional properties, test method and test report of products produced by additive manufacturing other than traditional processes.

5.2 Specimen preparation

5.2.1 For the powder bed melting process, normally the specimen can be manufactured separately from the product (3D printing), if for approval, the specimen is to be made (printed) on the product.

5.2.2 For arc fuse deposition and directional deposition processes, the specimen should be printed along with the product.

5.2.3 Due to the anisotropic characteristics of additive manufactured products, the direction of tensile, impact, fatigue and bending specimens is to be perpendicular to the delivery/extrusion direction of powder or wire, that is, sampling should be taken in the direction where the mechanical properties of the additive manufactured products are poor. The sampling orientation and position of additive manufactured products is to comply with the requirements in ISO/ASTM 52921.

5.2.4 Sampling group and batch is to comply with the relevant requirements of ISC Rules for Materials and Welding, in addition to that, the relevant recognized standards on this may be referred to with the consent of ISC.

5.3 Additional features of additive manufactured products

5.3.1 In addition to the general mechanical properties and physical and chemical properties, the following special additional properties are to be considered for the products manufactured by additive manufacturing process, which are to be inspected according to the requirements in Table 4.3.2.1:

- (1) Surface characteristics: appearance and surface roughness;
- (2) Geometry: tolerance of dimension, length and angle, etc.;
- (3) Mechanical characteristics: hardness and fatigue performance, etc.

5.4 Inspection basis

5.4.1 In addition to meeting the recognized standards listed in Table 5.4.1 of this Chapter, inspection of additive manufactured products is also to meet the relevant requirements in ISC Rules for Materials and Welding, Rules for Classification of Sea-going Steel Ships and Guidelines for Survey of Marine Products.

Inspection and Test Basis for Additive Manufactured Products **Table 5.4.1**

| Properties | Items | Recognized standards to be referred to in addition to ISC Rules for Materials and Welding ^③ | |
|-------------------------|--------------------------------|---|--------------------------|
| | | Metal | Plastics |
| Appearance and geometry | Appearance test | ② | ② |
| Mechanical properties | Hardness | ISO 6507 | ISO 2039 ISO 868 |
| NDT | Magnetic particle testing ① | ISO 9934-1 | - |
| | Penetrant testing | ISO 3452-1 ISO 3452-2 | ISO 3452-1 ISO 3452-2 |

① For ferromagnetic materials only;

② Other equivalent recognized standards may be referred to with the consent of ISC;

③ The Guidelines only list the common metal and plastic materials. If other materials are involved in the additive manufacturing design, relevant recognized standards may be referred to with the consent of ISC.

5.5 Acceptance criteria

5.5.1 The inspection results of the products prepared by additive manufacturing are to comply with the requirements of relevant recognized standards or the acceptance criteria set by design.

5.6 Test report

5.6.1 Due to the unique characteristics of each additive manufactured product, the descriptions of specimens of each batch of products, their processing and post-treatment are to be recorded in the test report and submitted to ISC. Test reports for product specimens prepared by additive manufacturing can record the required data and information as described below. Upon satisfactory results, ISC is to issue a certificate to the manufacturer and attach the relevant details.

5.6.2 Test reports of products made by additive manufacturing process are to include at least the following contents, if otherwise agreed by the two sides, this should be agreed by the ISC Surveyor:

- (1) Shape, size and allowable tolerances of the specimen;
- (2) Direction and position of the specimen in the molding chamber;
- (3) Specimen preparation process, adjustment process and various technological parameters;
- (4) Test direction of the specimen;
- (5) If the specimen is post-treated, the post-treatment process information is to be recorded. Post-treatment includes, but is not limited to, de-bracing, stress relieving, product combination, heat treatment and surface processing;
- (6) Standards used;
- (7) Results and dates of each test.

Appendix A Documents to be submitted for approval of additive manufacturing raw materials, products and repair processes

A.1 Scope

This appendix specifies the approval documents of additive manufactured products and additive repair that are to be submitted by manufacturers.

A.2 Documents to be submitted for approval of additive manufacturing raw materials, products and repair processes

(1) Raw materials and protective gases: the performance of raw materials can greatly affect the properties of the product, and the storage environment, reuse and batch of raw materials can lead to significant changes of product properties. Therefore, the raw material manufacturers are to submit to ISC the documents on input control, storage, handling conditions, vacuum degree and monitoring of raw materials such as powder or wire and protective gases.

(2) Additive manufactured equipment: documents on the additive manufactured equipment, including the main structure, relevant limitations, controllable parameters and associated production recording system. Documents describing the maintenance plan for additive manufactured equipment.

(3) Operators of additive manufactured equipment: documents on the qualifications of an additive manufactured equipment operator.

(4) Data control and database establishment: all processes of additive manufacturing are completed with the aid of computers, so it is necessary to record and statistically analyze relevant important process data, such as process temperature, environmental conditions, process progress, speed and other parameters. The process repeatability and product quality determine the necessity and scope of monitoring. The manufacturer is to submit to ISC documents describing the products used for additive manufacturing and related management. The type of software used to generate the 3D model, production document of additive manufactured equipment and records of equipment parameters are also to be submitted. In general, a frame diagram of the application of additive manufacturing database may be referred to in Appendix C of this Chapter.

(5) Process qualification: the certification document of granting the additive manufacturing process qualification to the manufacturer

(6) Quality control: documents on general inspection and testing of the product throughout the whole additive manufacturing process.

(7) Post-processing: documents of post-processing.

Appendix B Flowchart of Application of Industrial CT detection in Additive Manufacturing

B.1 This Appendix shows the flowchart of application of industrial CT detection in additive manufacturing.

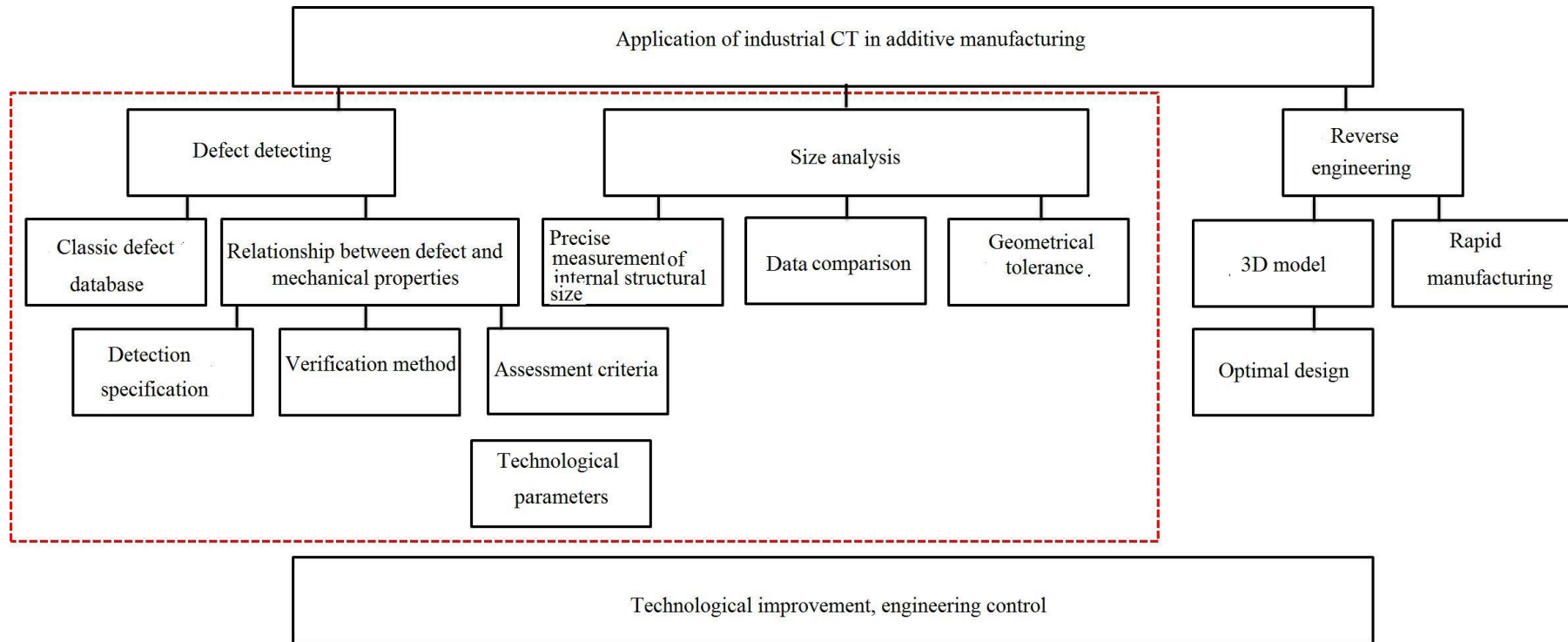

Figure B.1 Flowchart of Application of Industrial CT detection in Additive Manufacturing

Appendix C Frame Diagram of Additive Manufacturing Database

C.1 This appendix shows the frame diagram of additive manufacturing data control and database establishment.

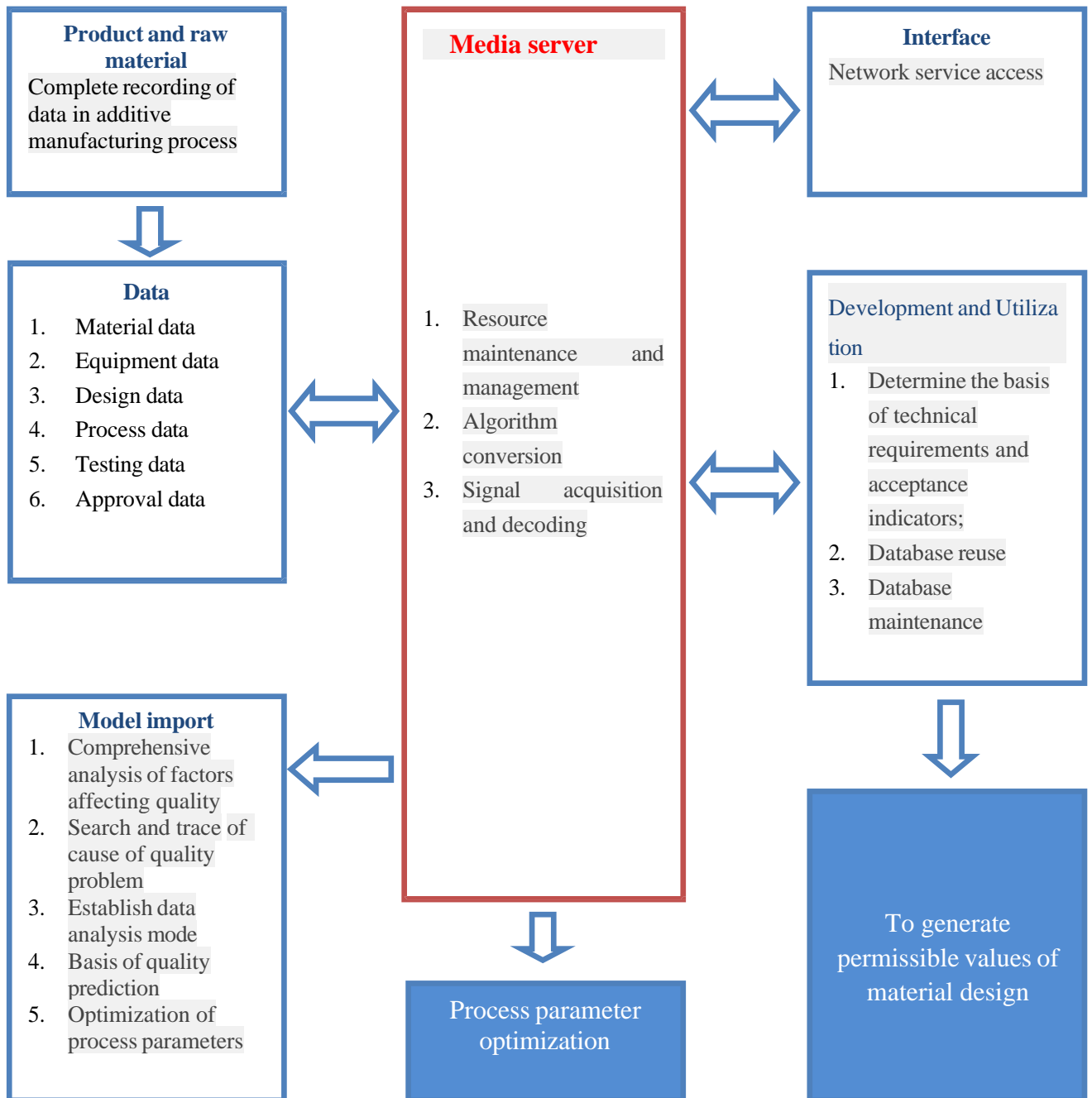

Figure C.1 Frame Diagram of Additive Manufacturing Database